

Models 83E

Ergonomic Vertical "Eye" Coil Lifter

Product Features:

- Efficient handling of vertically stacked coils
- Handles coils with I.D.'s of 16", 20", and 24"
- Ergonomic handles and guide
- Horizontal handle with pin lever is easy to actuate
- Spring-loaded lever can be set for right- or left-handed operation
- Unique 360° guide handle is easily accessed from any location
- Optimized foot accommodates 5/8" blocking
- Complies with ASME standards

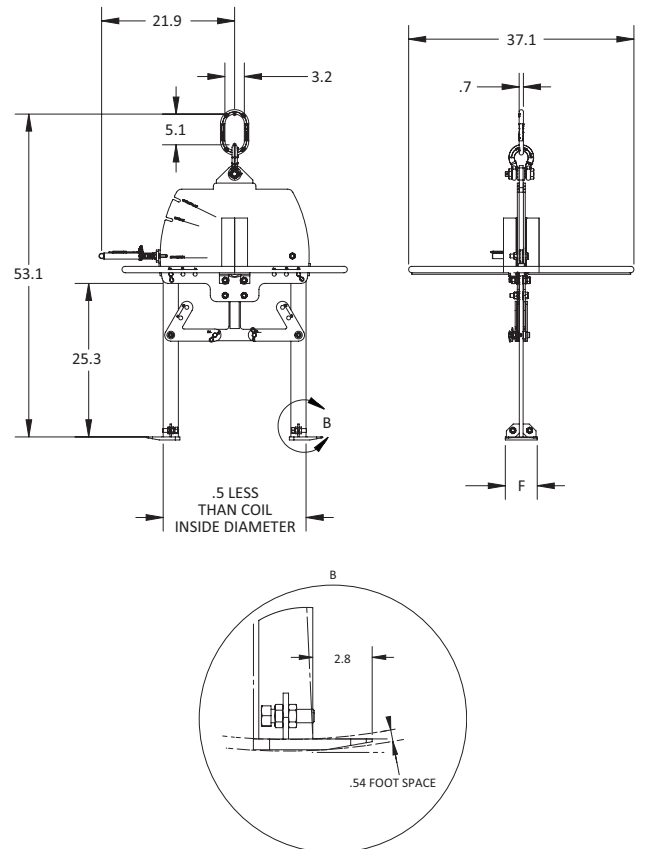
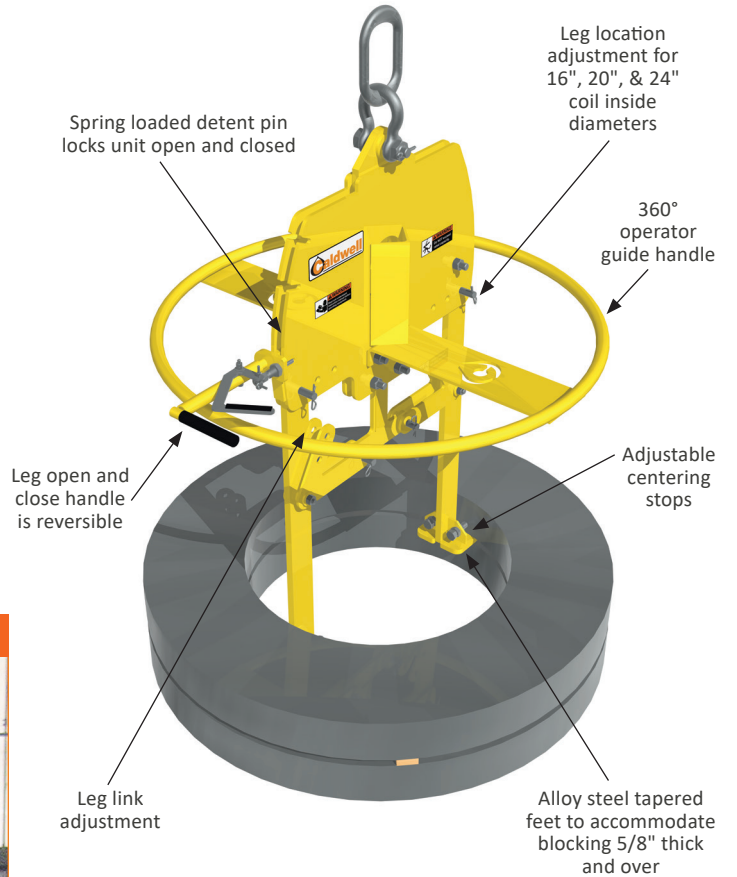

Model Number	Rated Capacity (tons)	F (in.)	Weight (lbs.)
83E-3-16/20/24	3	5.3	160
83E-5-16/20/24	5	8	165