

# Model 90

## Standard Fixed-Forks Pallet Lifter

Pick the capacity, fork length, and bail placement that works for your application. With 16 different configurations in our standard lineup, you're sure to find the one that works for you.

Need something different? See the Lightweight and Heavy-Duty models for more options or create a custom design to fit your exact specifications. Call 800.628.4263 for details.

### Product Features:

- Converts overhead crane to lift truck
- Counterbalanced to hang level when empty
- Maintenance-free
- Allows for ease of loading/unloading in not easily accessible areas
- Complies with ASME standards

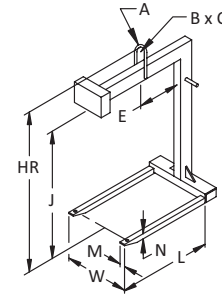

Model Number	Capacity (tons)	Dimensions (in.)										Weight (lbs.)
		Forks				E	Bail			J*	HR	
		L	M	N	W		A	B	C			
90-1-36	1	36	2	2	25	18	1	6	5	48	57-1/2	292
90-1-42	1	42	2	2	25	21	1	6	5	48	57-1/2	310
90-1-48	1	48	2	2	25	24	1	6	5	48	58-1/2	371
90-1 1/2-36	1-1/2	36	3	2	25	18	1	6	5	48	58-1/2	388
90-1 1/2-42	1-1/2	42	3	2	25	21	1	6	5	48	58-1/2	432
90-1 1/2-48	1-1/2	48	3	2	25	24	1	6	5	48	58-1/2	459
90-2-36	2	36	3	2	25	18	1	6	5	48	59-1/2	448
90-2-42	2	42	4	2	25	21	1	6	5	48	59-1/2	536
<b>IN STOCK</b> 90-2-48	2	48	4	2	25	24	1	6	5	48	59-1/2	627
90-3-42	3	42	4-1/2	2-1/2	25	21	1-1/2	6-1/8	7	48	61-1/2	766
<b>IN STOCK</b> 90-3-48	3	48	4-1/2	2-1/2	27	24	1-1/2	6-1/8	7	48	61-1/2	823
90-3-54	3	54	4-1/2	2-1/2	30	27	1-1/2	6-1/8	7	48	61-1/2	969
90-4-48	4	48	5	3	27	24	1-1/2	6-1/8	7	48	63-1/2	1176
90-4-60	4	60	5	3	30	30	1-1/2	6-1/8	7	60	75-1/2	1393
90-5-48	5	48	5	3	30	24	1-1/2	6-1/8	7	48	63-1/2	1193
90-5-60	5	60	5	3	38	30	1-1/2	6-1/8	7	60	75-1/2	1403

\* Additional 3" - 4" clearance recommended above load for ease of loading and unloading the lifter.

# Model 93W

## Wheeled Pallet Lifter

Your material handlers will thank you for making it easier to move this unit from crane bay to crane bay or from one end of your facility to the other. Just tilt and roll.

### Product Features:

- Wheels allow for movement of unit without crane
- Dual lift points eliminate need for counterweight
- Extremely lightweight for ease of handling
- Complies with ASME standards

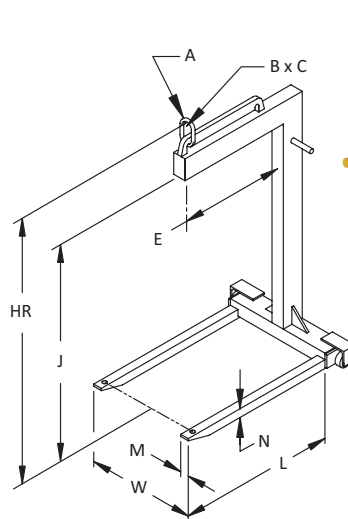

Model Number	Capacity (tons)	Dimensions (in.)										Weight (lbs.)
		Forks				E	Bail			J	HR	
		L	M	N	W		A	B	C			
93W-1-48	1	36	2	2	25	24	1/2	2-1/2	3-3/4	48	60	245
93W-2-48	2	36	4	2	25	24	3/4	2-3/4	4-1/2	48	62	405