

Pallet Lifters

Model 93W - Wheeled Pallet Lifter



PRODUCT FEATURES:

- Wheels allow for movement of unit without crane.
- Dual lift points eliminates need for counterweight.
- Extremely lightweight for ease of handling.
- Complies with ASME standards.

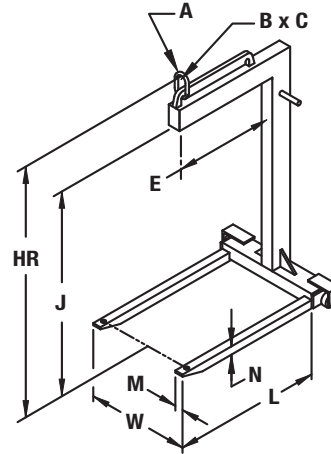

QUICKSHIP PROGRAM

SPECIFICATIONS

Model Number	Capacity (tons)	Dimensions (inches)										Weight (lbs.)
		Forks					Bail					
		L	M	N	W	E	A	B	C	J	HR	
93W-1-48	1	36	2	2	25	24	1/2	2-1/2	3-3/4	48	60	245
93W-2-48	2	36	4	2	25	24	3/4	2-3/4	4-1/2	48	62	405

Model 94 - Lightweight Pallet Lifter



QUICKSHIP PROGRAM

PRODUCT FEATURES:

- Dual lift points eliminates need for counterweight.
- Extremely lightweight for ease of handling.
- Maintenance free - no moving parts.
- Complies with ASME standards.

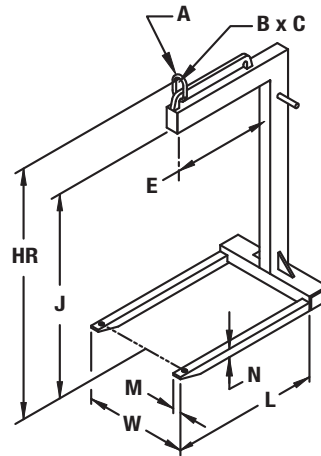

SPECIFICATIONS

Model Number	Capacity (tons)	Dimensions (inches)										Weight (lbs.)
		Forks					Bail					
		L	M	N	W	E	A	B	C	J	HR	
94-1-48	1	36	2	2	25	24	1/2	2-1/2	3-3/4	48	58	245
94-2-48	2	36	4	2	25	24	3/4	2-3/4	4-1/2	48	62	425
94-3-48	3	36	4-1/2	2-1/2	27	24	1	3-1/2	5	48	65	610