

# Motorized Rotating Crane Hooks

## Clevis Style

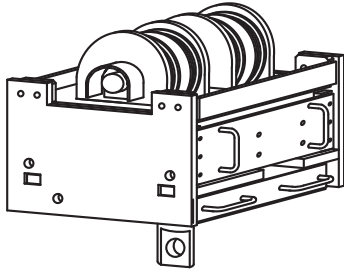

## Pin Bail

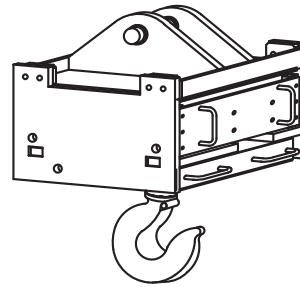

## Motorized Rotating Crane Hook Application Evaluation

1. CMAA Crane Duty Class (A, B, C, D, E, F): \_\_\_\_\_
2. Capacity of crane: \_\_\_\_\_
3. Number of sheaves: \_\_\_\_\_
4. Sheave diameter: \_\_\_\_\_
5. Sheave spacing (A): \_\_\_\_\_ (X): \_\_\_\_\_
6. Type of sheave bearings: \_\_\_\_\_
7. Wire rope diameter: \_\_\_\_\_
8. Maximum degree of rotation required: \_\_\_\_\_
9. Will a motorized grab be suspended from the hook?  
 Yes     No
10. Operating voltage: \_\_\_\_\_
11. Headroom Dimension: \_\_\_\_\_

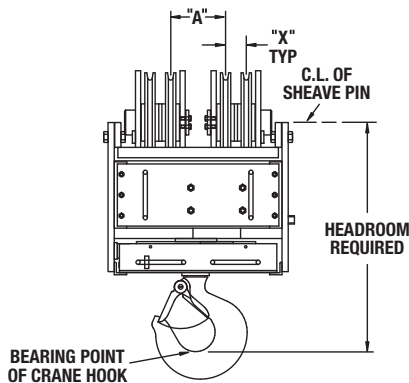

12. Describe load to be rotated:
  - a. Weight \_\_\_\_\_
  - b. Length \_\_\_\_\_
  - c. Width \_\_\_\_\_
  - d. Height \_\_\_\_\_
  - e. Shape \_\_\_\_\_
13. Will hook be exposed to a high temperature environment?     Yes     No
14. Will hook be outdoors?     Yes     No
15. Operation controlled from:
  Cab     Pendant     Remote
16. Load scale required?     Yes     No

Describe requirements:

\_\_\_\_\_

\_\_\_\_\_

\_\_\_\_\_

17. Options required:

Contact: \_\_\_\_\_

Company: \_\_\_\_\_

Address: \_\_\_\_\_

City, State, Zip: \_\_\_\_\_

Phone: \_\_\_\_\_

Fax: \_\_\_\_\_

Email: \_\_\_\_\_

For a price quote on your specific application, please complete the above form and fax to The Caldwell Group at **815-229-5686** or you can complete this form online at [www.caldwellinc.com/applications](http://www.caldwellinc.com/applications).