

Posi-Turner® Application Evaluation

PRODUCT:

Product to be handled _____

Maximum: Weight _____ Length _____ Width _____ Height _____

Minimum: Weight _____ Length _____ Width _____ Height _____

Off-centered weight (detailed drawing mandatory) _____

Does product have: Sharp Edges/Corners Protrusions Welding Application

Is temperature of product at time of handling over 150° F? No Yes Temperature: _____

Type of slings preferred: Polyester Steel Mesh Chain

Decision time frame and expected delivery: _____

WORK AREA:

Lifting device available: Crane Gantry Fork Lift Lifting Capacity: _____

If two cranes/hooks are available, can they be used for this application? Yes No

If yes, what is the crane hook spacing: Minimum _____ Maximum _____

Do you prefer to supply power for Posi-Turner® from: Crane Floor Level

Headroom clearance (hook to floor): _____

Is product lifted from: Floor Conveyor Worktable Other

Height of conveyor/worktable (Inches): _____

Will product be rotated over conveyor/worktable: Yes No

Amount of rotation: 90° 180° 360°

Work Area Conditions: Outside Inside Welding Area Corrosive

Describe any hazardous conditions: _____

POWER REQUIREMENTS:

Electrical: DC AC Voltage _____ Phase _____ Cycle _____

Pneumatic: Pressure _____ Flow _____ Line Size _____

Hydraulic: Pressure _____ Flow _____ Line Size _____

Other: _____

Posi-Turner® control system preferred: Pendant Radio Infrared Remote P.B.

OTHER OPTIONS:

- Auto-Leveler™
- Castor Wheels
- See pages C.10 & C.11 for details. Power Cord Reel
- Pendant Cord Reel
- Sling Link Covers
- Sling Guides
- Other _____

Contact: _____

Company: _____

Address: _____

City, State, Zip: _____

Phone: _____ Fax: _____

Email: _____

CRANE HOOK DIMENSIONS:

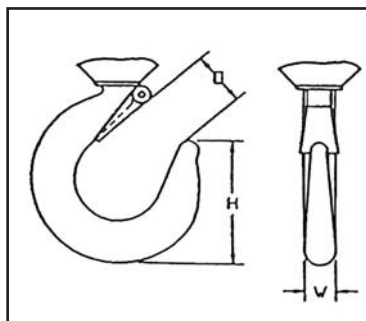

_____ (O) Opening
(including safety latch)

_____ (H) Height

_____ (W) Width

For a price quote on your specific application, please complete the above application form and fax this along with a photo, sketch, or drawing of the product being rotated, to **815-229-5686** or you can complete this form online at www.caldwellinc.com/applications.