

Lifter LockOut™

Lifter LockOut™ Set Up

- Compression springs are configured to accommodate the pre-load weight of the lifter.
- Four, six or eight springs can be used in addition to screw cap adjustment for precision configuration of the lockout settings.
- Shackle lifting eye easily attached to many size crane hooks.
- Pin bail allows for easy attachment to most lifters.
- Maximum 30,000 pound capacity.
- Maximum lifter weight of 7,000 pounds.
- Designed for 480v/3ph/60hz power supply.

Custom Lifter LockOut™ Configurations:

- Special Voltages.
- Custom attachment point for lifter.
- Custom attachment to crane hook.
- Larger capacities.
- Heavier lifter weights.

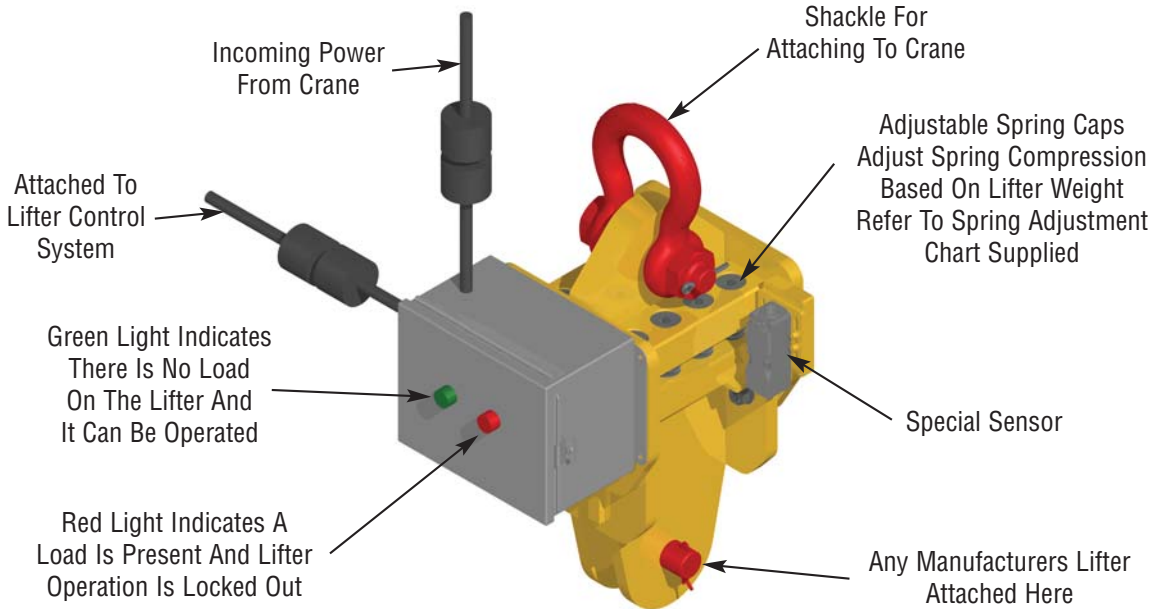

Special Designs Available
On Request

REQUIRED INFORMATION:

Lifter Weight: _____

Bail Opening Dimensions: _____

Load Weight: _____

Contact: _____

Company: _____

Address: _____

City, State, Zip: _____

Phone: _____

Fax: _____

Email: _____

CRANE HOOK DATA:

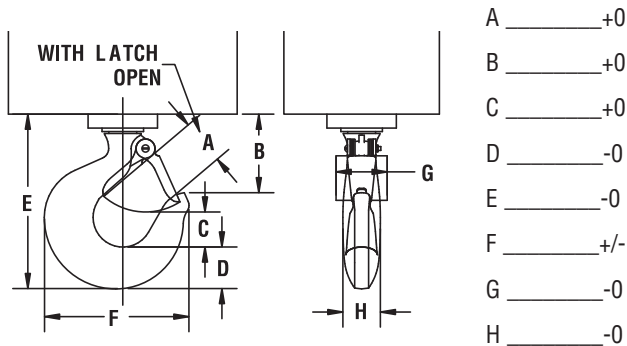

Measurement Tolerances

- +0 = Measurement should be no larger but can be smaller than actual.
- 0 = Measurement should be no smaller but can be larger than actual.
- +/- = Measurement can be larger or smaller than actual.

For a price quote on your specific application, please complete the above form and fax to The Caldwell Group at **815-229-5686** or you can complete this form online at www.caldwellinc.com/applications.