

Lifting Beams

Model 21 - Twin Hoist Rotating Lifting Beams

A specially designed lifting and rotating beam using two cranes or two hoists to horizontally rotate a load. A position locking pin holds the load rotation at a designated position. Available with motorized rotation.



PRODUCT FEATURES:

- Wide range of sizes and capacities available.
- Complies with ASME standards.

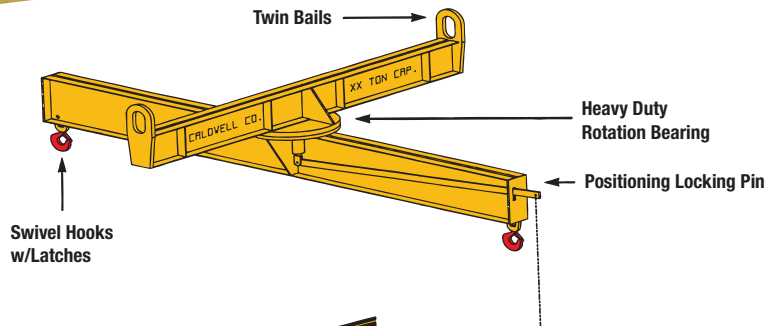

OPTION A

TWIN HOOKS

Used in conjunction with basket hitch slings.



OPTION B

J HOOKS

Generally required to lift paper rolls or similar application. (Use Paper Roll Lifters - Application Evaluation, page A.36.)

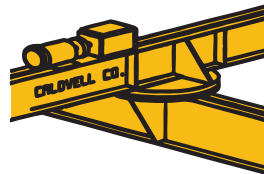

OPTION C

MOTORIZED ROTATION

Allows remote positioning of a load.



OPTION D

LOWER HEADROOM BAILS

Utilized when headroom must be held to a minimum. Crane hook data must be supplied, see page A.22.

Model 28 - Chlorine Cylinder Lifting Beam

Designed to efficiently handle standard chlorine gas cylinders. Standard size determined by the Chlorine Institute is 80-3/4" to 82-1/4" in length. Special low headroom modification is available.

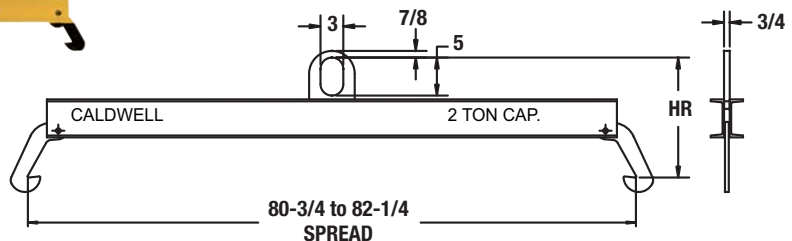

NOTE: All dimensions shown in inches.

QUICKSHIP PROGRAM

SPECIFICATIONS

Model Number	Capacity (tons)	HR Headroom (in.)	Weight (lbs.)
28-2-80/82	2	16-1/2 - 15-1/2	105